

# WORLD MARKET®

## Assembly Instructions

### Aurelia Flared Leg Desk

SKU 635512

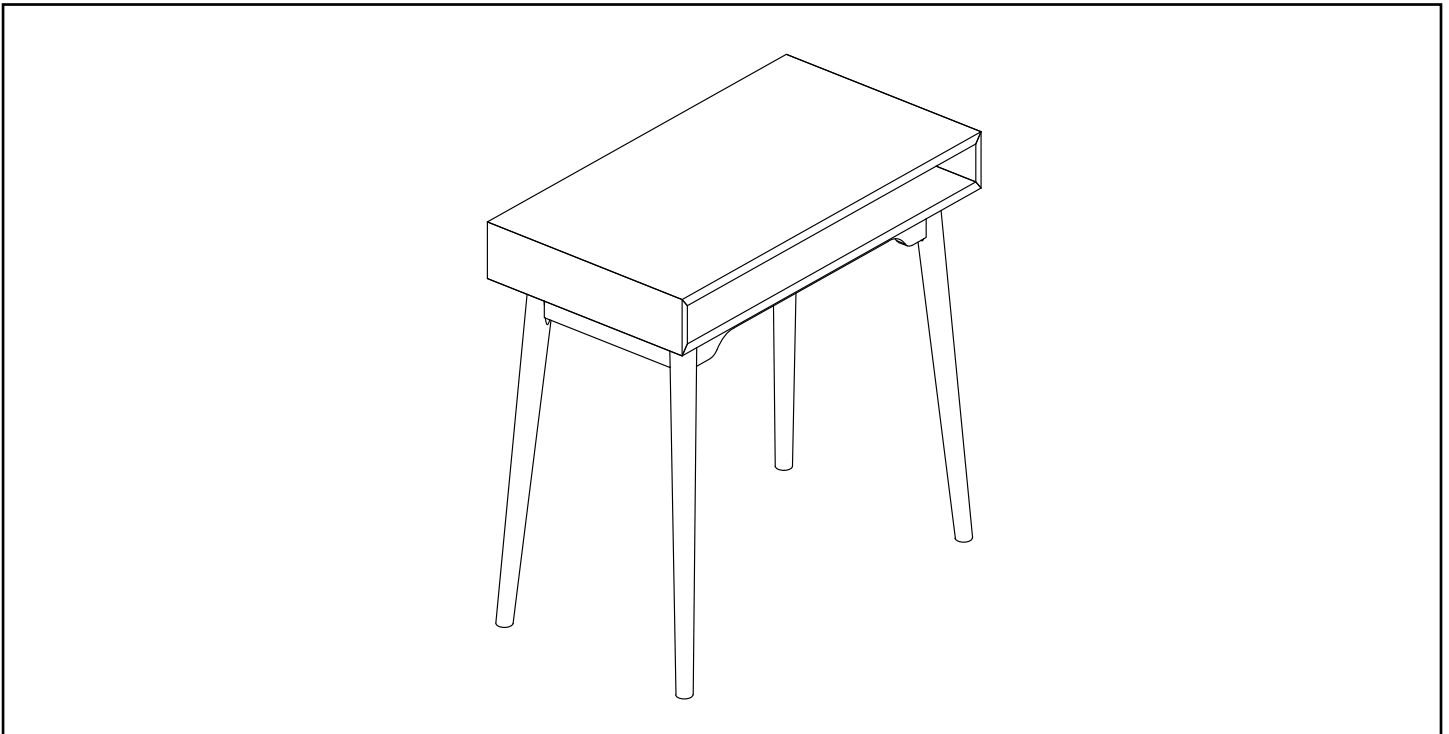



Thank you for your purchase. If you have any questions pertaining to the assembly of this furniture piece, please contact the nearest World Market store. If you are not near a store, please call our customer service call center toll free at 877-967-5362 for assistance.

ALL PRODUCTS SOLD AT WORLD MARKET ARE NOT  
FOR COMMERCIAL USE AND ARE INTENDED FOR  
RESIDENTIAL USE ONLY.

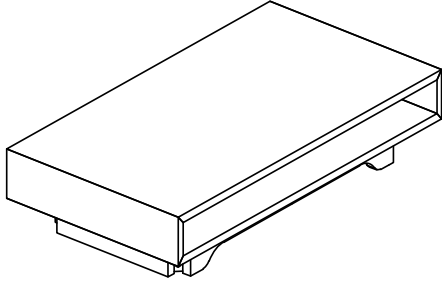
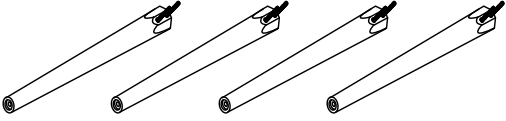
# Component List

LABEL	PICTURE	DESCRIPTION	QTY.
A		Desk Top	1
B		Legs	4

# Hardware List

LABEL	PICTURE	DESCRIPTION	QTY.
H-1		Nut 5/16"	8
H-2		Spring Washer 5/16"	8
H-3		Flat Washer 5/16"	8

# Tool List

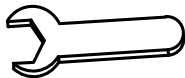
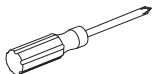
LABEL	PICTURE	DESCRIPTION	QTY
T-1		Wrench	1
T-2		Phillips Screwdriver(not included)	1

## IMPORTANT :

- 1.Do not tighten bolts completely until all bolts are completely lined up and inserted into holes / nuts.
- 2.Do not over tighten screws and bolts to avoid stripping.
- 3.Please use hand tools to assemble this product. Do not use power tools.
- 4.For ease of assembly, two adults are recommended.

# Assembly Preparation

Before Beginning:

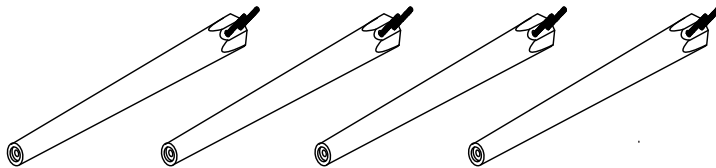
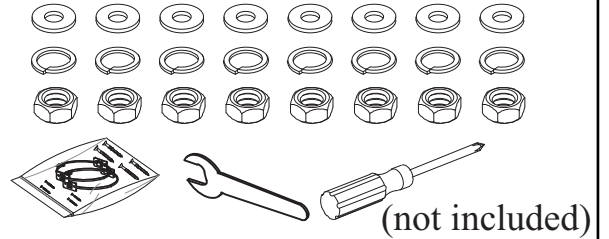
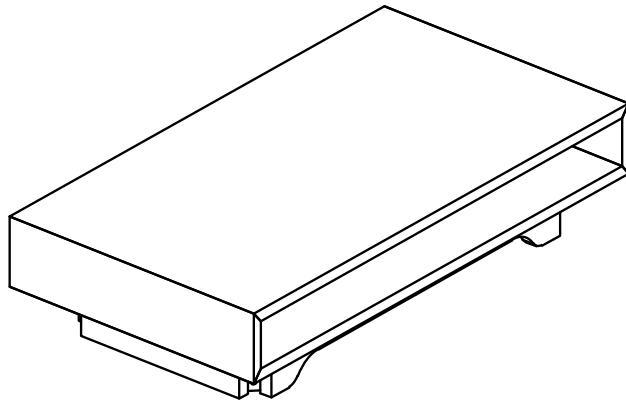

Unpack all hardware bags and components to ensure you have all parts. Take note of bolt hardware size differences and components that may have directional labels (Example: TOP or FRONT).



Read the assembly instructions, cover-to-cover. Save any **Care and Maintenance** instructions pages for after the assembly has been completed.



It is always recommended to have 2 adults on hand for assembly.



Do not assemble on hard, abrasive flooring or carpeted surfaces that can damage or get caught in the components during assembly.



Assemble on a clean non-marring surface (such as the product's packing foam).

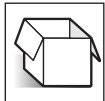

Do not discard any packaging until the product has been fully assembled.





In case of missing parts, please contact your nearest World Market store or call our customer service call center at 1-877-967-5362.



**WARNING:** Small parts are a choking hazard. Adult supervision is required before, during, and after assembly.

# Assembly Steps

## Step 1

-  (H-1) Nut x 08
-  (H-2) Spring Washer x 08
-  (H-3) Flat Washer x 08

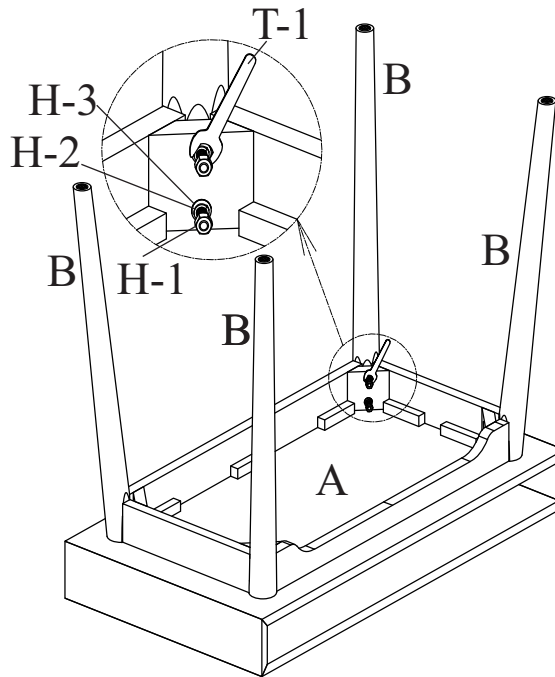

Carefully place Desk Top (A) upside down onto a padded, non-marring surface. Insert a Leg (B) at each corner of the Desk Top (A) as shown in the illustration, making sure the hanger bolts on the leg pass through the holes. Attach a Flat Washer (H-2), Spring Washer (H-3) and Nut (H-1) on each of the leg hanger bolts, stacking the hardware in the order as shown. Engage the Nut (H-1) by hand first then proceed to tighten in Step 2.

## Step 2

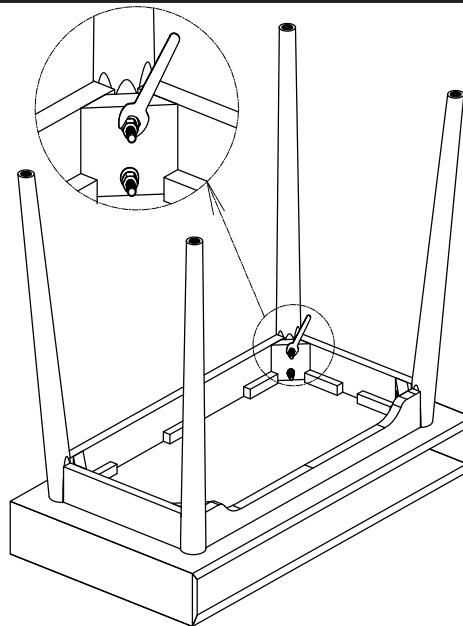

Once all of the leg hardware has been attached (in Step 1), fully tighten all 8 Nut (H-1) (two nuts per leg) by turning them clockwise until snug using Key Wrench (T-1).

# Assembly Steps

## Step 3

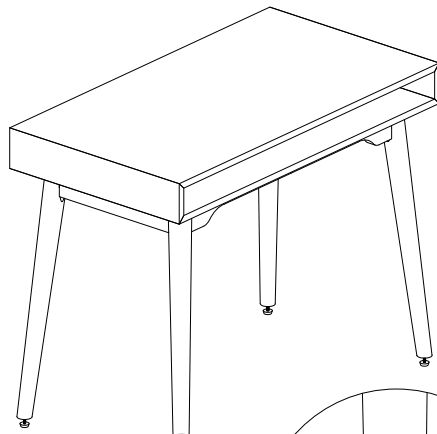

Levelers are located on the bottom of each leg and may be used for additional adjustment if needed for uneven surfaces.

Using a second person to assist you, carefully turn the assembled desk upright. Ensure that the desk rests evenly on all four legs and adjust the levelers on the bottom of each leg as needed.

## Finish

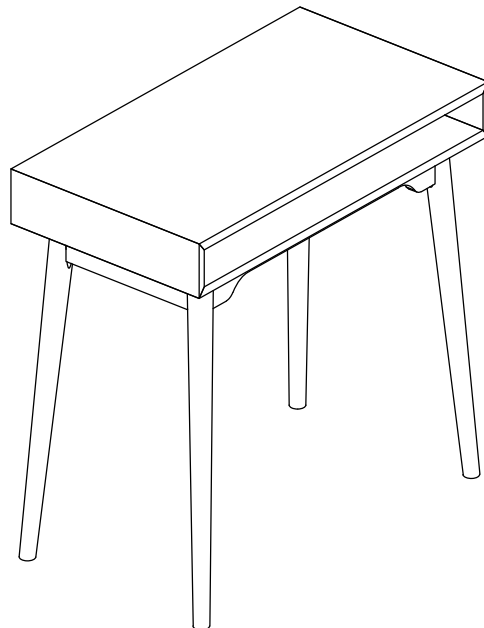

Assembly is now complete and the product is ready for use.

NOTE: Hardware may loosen over time and with use. Periodically check that all connections remain fully tightened and adjust as needed.

# Anti-Tip Measures

## WARNING

Furniture tip overs can result in death or serious injuries. To reduce the likelihood of tip over, this product should be used with the enclosed Anti-Tip Kit. This Anti-Tip Kit is only a deterrent. It is not a substitute for proper adult supervision. Manufacturer and retailer assume no liability for improper installation or excess loads placed on screws, brackets, or straps. When properly installed, this restraint provides protection against unexpected tipping of furniture. This Anti-Tip Kit **MUST** be installed into the wall using proper mounting hardware **OR** into a wall stud using appropriate screws. Position of the Anti-Tip Kit depends on the product and the location of the wall studs. The hardware provided is not a comprehensive solution for all wall types. Be sure to consult a professional or your local hardware store to determine the hardware needed for your specific wall type (plaster, drywall, concrete, etc.).

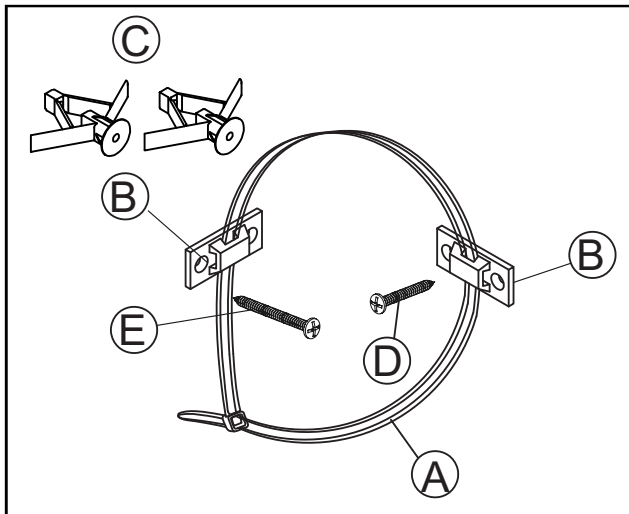

Anti tip kit contents

TIPPING KIT CHECK LIST		
CODE	COMPONENT	QTY
A	NYLON RESTRAINT STRAP	1
B	MOUNTING BRACKET	2
C	WALL ANCHOR	2
D	SHORTER SCREW	2
E	LONGER SCREW	2

### Step 1.

Brackets (B) will be installed in the wall to correspond with additional Brackets (B) installed on the desk (in Step 2). Use Step 2 to determine bracket spacing. Pre-drill holes in the wall using the appropriate tools and hardware for your wall type (not included). Insert a Wall Anchor (C) into each hole in the wall and then align a Bracket (B) with each anchor hole. Secure the Wall Anchors (C) and the Brackets (B) using Longer Screws (E) and a Phillips screwdriver (not included).

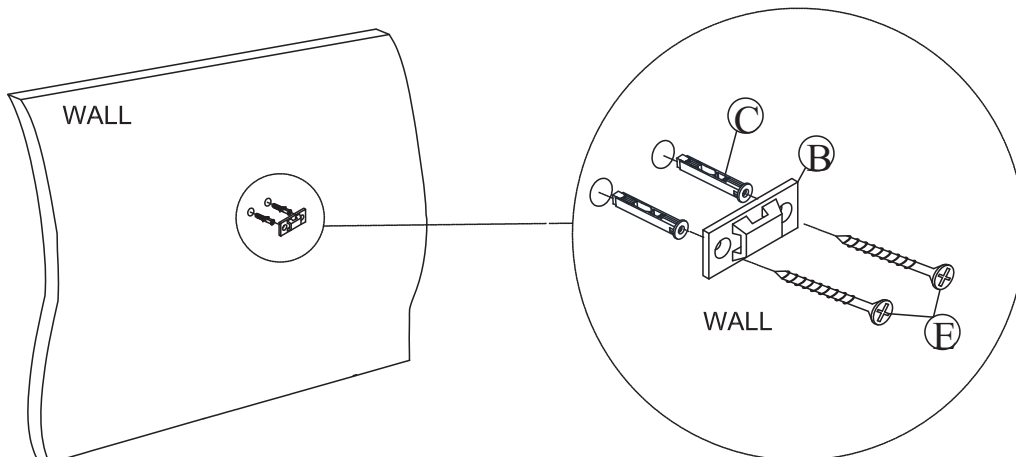

Step 2: Attach mounting bracket (B) to the back of the product with short screw (D).

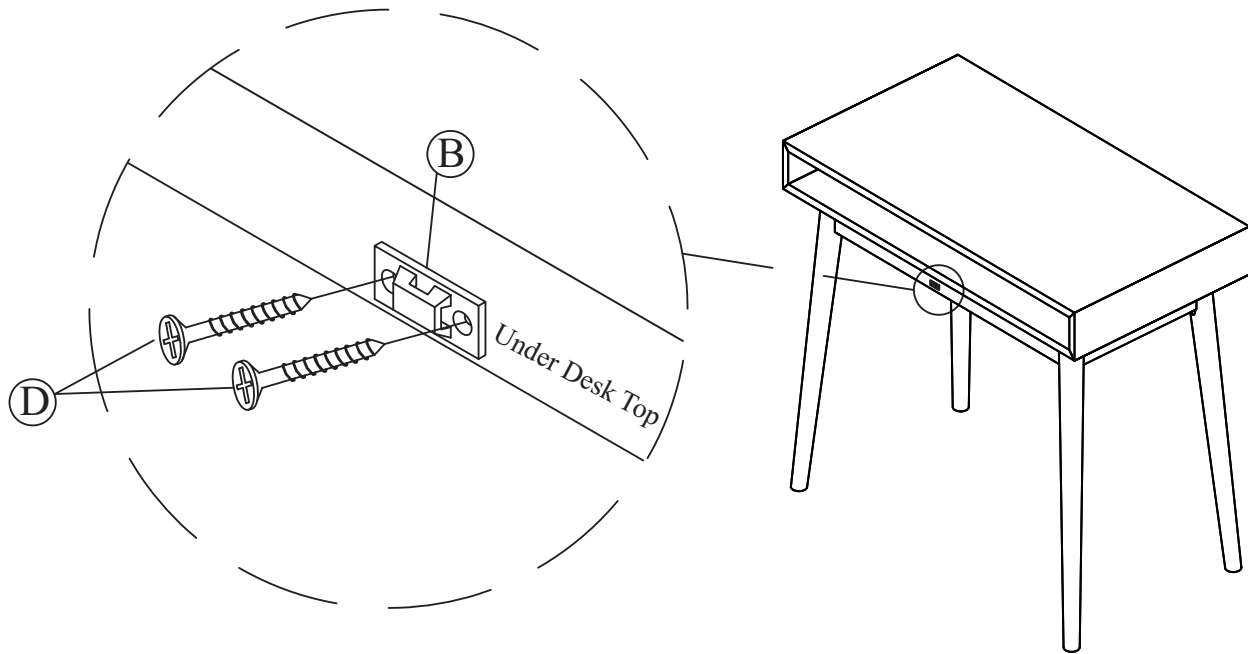

Step 3: Slide the strap (A) through the mounting brackets and pull to tighten the product snug against the wall.

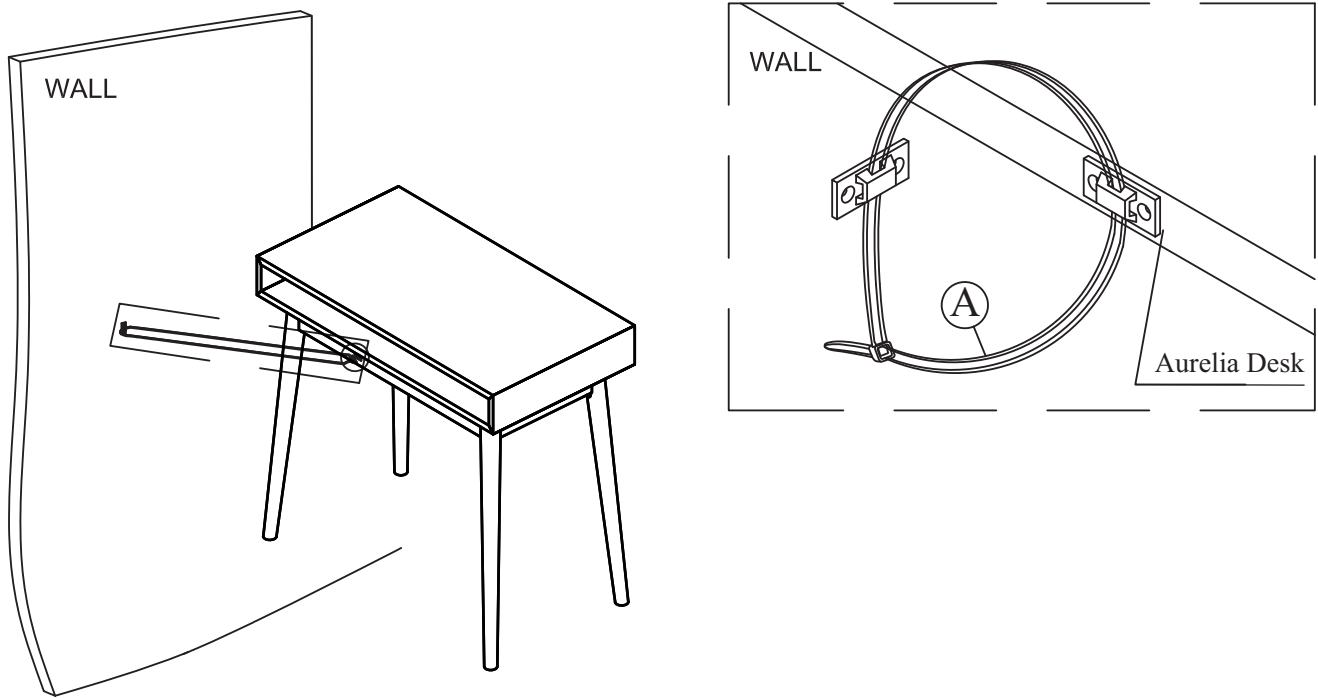

Manufacturer name: HUNG NGOC CO., LTD

Manufacturer add: TAN VINH HIEP WARD, TAN UYEN VILLAGE, BINH DUONG PROVINCE, VIETNAM.

Date of manufacture: 01/2024

# COMPLETED ASSEMBLY

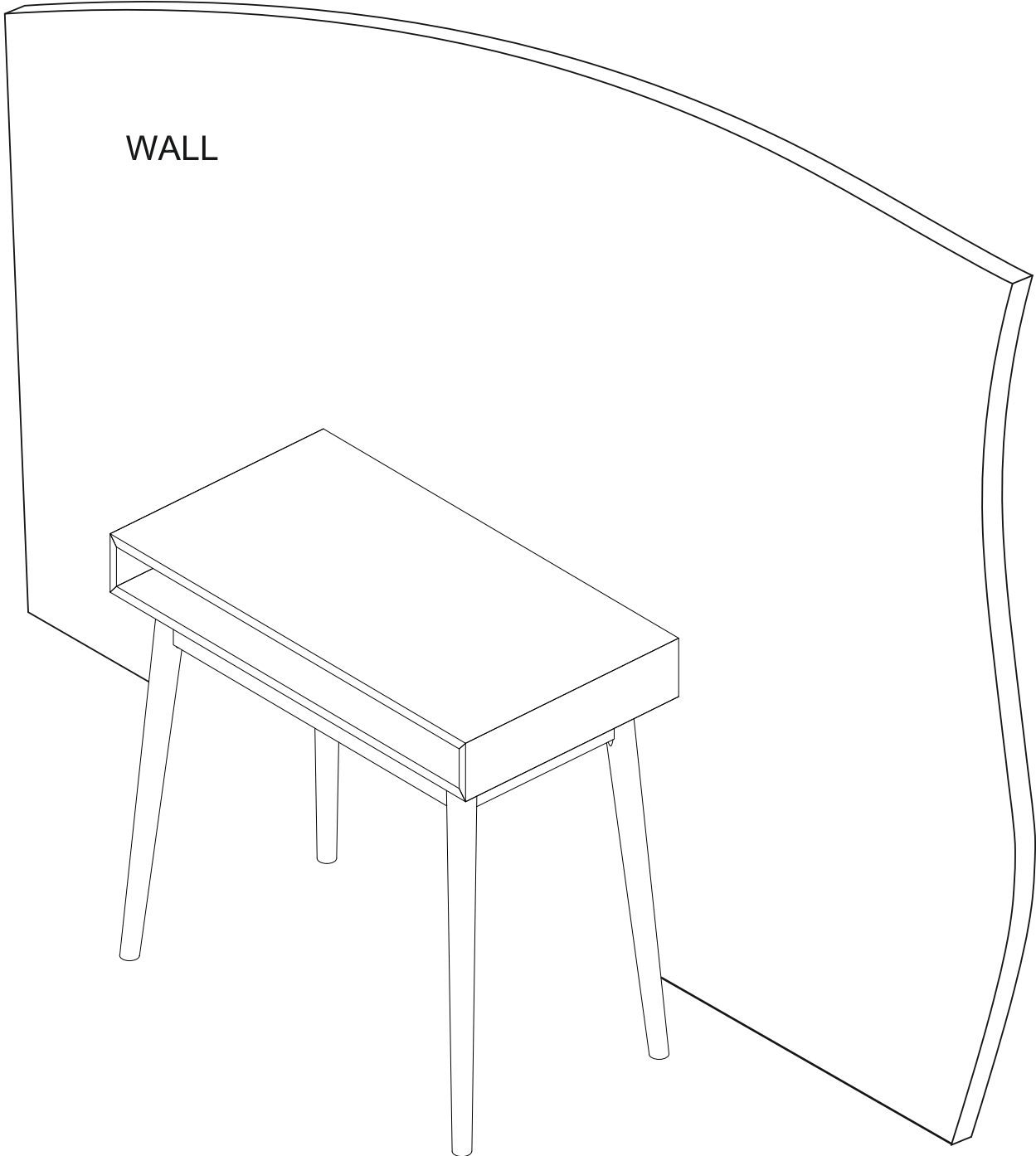



# Warnings

## ⚠ WARNING



**Children have died from furniture tip over. To reduce the risk of furniture tip over:**

- **ALWAYS** install Anti-Tip device provided.
- **NEVER** put a TV on this product.
- **NEVER** allow children to stand, climb or hang on any drawers, doors or shelves.
- **NEVER** open more than one drawer at a time.
- **DO NOT** defeat or remove any drawer interlock system if included with the product; it is an important stability and safety system.
- **Place heaviest items in the lowest drawers.**



Not intended for clothing storage use.



All products sold at World Market are not for commercial use and are intended for residential use only.

# Care & Maintenance



**DO NOT** put hot items directly on furniture surface.



**DO NOT** clean furniture with harsh cleansers or polish.



**DO NOT** place furniture in direct sunlight.



**DO NOT** place furniture near heating or cooling vents.



**DO NOT** write on furniture without a padded barrier to protect the surface.



**DO NOT** place furniture outside. For INDOOR USE ONLY.



Dust and pick up spills using a clean, non-colored, lint-free dry cloth.

# **WORLD MARKET** LIMITED ONE-YEAR WARRANTY – Indoor Furniture

For your customer satisfaction, this product carries a LIMITED ONE-YEAR WARRANTY from the date of delivery. This limited warranty only applies to World Market brand furniture, and not to other furniture brands sold on World Market's website.

Where applicable, the limited warranty provides coverage for:

1. **Manufacturing, Material and Workmanship Defects:** Includes defects related to core frame/structure substrates (wood and metal); cracking, splitting, or complete breakage of hardwood, plywood or medium density fiberboard (MDF); cracking, splitting or lifting of wood veneer or laminated top surfaces caused by process failure; broken welds or improperly coated metal frame components (powder coating or painted); fabric or leather material defects including tears, misprints, fraying, crease marks, skip stitches or open seams; support webbing material and sinuous spring defects or damage, including method of attachment to frame; and other component failures that are a direct result of manufacturing or workmanship defects.
2. **Cushions & Cushions with Enclosed Steel Pocket Coils:** Failed or ruptured steel pocket coils enclosed inside of seat cushions, or loss of resiliency from a material breakdown of foam or fiber filling, which should not be confused with softening or settling during normal use.
3. **Leather:** Splitting or cracking of leather material. NOTE: The warranty does NOT cover natural hide markings, variations in the leather color or grain due to the authentic natural properties of processed cowhide leather.
4. **Bonded Leather or Bi-cast Leather:** Separation of the polyurethane coating, peeling or cracking of the inner layer or at the bonded seam edges (bi-cast straps).
5. **Furniture Components (Hardware & Mechanisms):** Includes defects to pre-installed components or hardware provided to the customer for assembly such as office chair hydraulic lifts, lift mechanisms, metal bases and casters, swivel plate mechanisms; for drawers, metal glides, handles/knobs; for doors, hinges, magnetic latches; and other components such as bent or stripped threaded leg posts and adjustable levelers. For missing, damaged, corroded, or misplaced hardware components such as bolts or washers, please contact Customer Service at: 877-967-5362.

## **This LIMITED ONE-YEAR WARRANTY does NOT cover:**

1. Damage due to mishandling during transportation from store or transportation without original protective packaging.
2. Abuse, negligence (product misuse) or wear and tear that may result in or from:
  - a. **Wood & Veneer:** Mishandling, exposure to moisture, peeling or discoloration caused by exposure to moisture or excessive sunlight, heat; splintered, dented or nicked panels, legs or component edges or paint/finish blemishes; or treatment with corrosive chemicals (dyes, inks, paints or harsh cleaning products).
  - b. **Fabric & Leather (Including Bonded or Bi-Cast Leathers):** cuts, punctures, tears, burns, pet damage, or treatment with corrosive chemicals (dyes, inks, paints or harsh cleaning products), exposure to direct sunlight, fire, high heat, water, or any bright light source (natural or artificial) that may cause splitting, peeling or flaking with time.
  - c. **Foam (Cushions):** Flattening, relaxing or settling/softening of foam components that comes with normal use.
  - d. **Hardware Components:** improper installation or misuse/substitution of hardware components not defined in the Assembly Instructions for the product (if applicable)
3. Damage due to environmental exposure to direct sunlight, fire, high heat, water or extreme humidity, any bright light source (natural or artificial), or any environment that the product is not intended for.
4. This warranty is applicable for indoor furniture products purchased for residential use only.

For additional information on returns, please visit: <https://www.worldmarket.com/category/customer-service/returns.do>

**All products sold at World Market are NOT FOR COMMERCIAL USE and are intended for residential use only. Products purchased for commercial use will VOID all warranty provisions as listed above.**

Any claims under this LIMITED ONE-YEAR WARRANTY are valid and applicable only as to the original purchaser and must be accompanied by proof of purchase. Warranty claims should be submitted to a World Market store or through World Market Customer Service Call Center, Toll Free at 877-967-5362.

For valid warranty claims, World Market will repair or replace the product, or offer a full or partial credit, in the sole discretion of World Market. This LIMITED ONE-YEAR WARRANTY gives you specific legal rights and you may also have other rights which vary from state to state.